

WT-1010C2

GSM ALARM SYSTEM

User Manual



WITURA

WITURA CORPORATION SDN BHD

Contents

1. Getting Started	4
1.1 In the Packaging.....	4
1.2 Viewing the WT-1010C2.....	4
2. Introduction to WT-1010C2 GSM Alarm System.....	5
2.1 General Overview.....	5
3. Main Features of the WT-1010C2.....	6
4. Installation Instructions.....	8
4.1 External Connections Diagram.....	8
4.2 Wiring Diagram A (Main Unit)	9
4.3 Wiring Diagram B (DB15 Female Cable).....	9
4.4 Description.....	9
4.5 WT-1010C2 Inputs & Outputs Wiring Instructions.....	10
4.6 Installing the SIM Card.....	11
4.7 Power up the WT-1010C2	12
4.8 Dialing a Number From the Attached Telephone Set.....	12
5. WT-1010C2 Configuration Instructions (Via Fixed Line Phone).....	13
5.1 Introduction.....	13
Step1- Enter Programming Mode.....	13
Step2- Reset the WT-1010C2 Unit.....	14
Step3- Programming the Administrator.....	14
Step4- Setting the Recipient that will receive Alert Messages.....	15
Step5- Programming the Area Code.....	16
Step6- Setting the Function of Adding Area Code when Transmitting an Alarm.....	16
Step7- Setting the Delay Time for Transmitting a Dialing Number.....	17
Step8- Setting for Calling a Group of Administrator.....	17
Step9- Setting for Auto Test.....	18
Step 9.1 Time Setting.....	18
Step 9.2 Setting the Auto Test Report Time Section 1.....	18
Step 9.3 Setting the Auto Test Report Time Section 2.....	19
Step 9.4 Setting the Auto Test Report Time Section 3.....	19
Step 9.5 Enable/Disable the Function of Dialing the Programmed Administrator Number for Auto Test.....	20
Step 9.6 Enable/Disable the Generation of SMS Report for Auto Test.....	20
Step 9.7 Setting the Burst On and Burst Off time of DTMF tones.....	21
Step10- Setting for PSTN Failure.....	22
Step11- Setting for AC Failure.....	23
Step12- Setting for Overcoming GSM Jammers & GSM Tower Failure.....	24
Step 12.1 Enable/Disable the Function of Activate Output Relay 1 when GSM Jammers is detected	24
Step 12.2 Setting the Parameter for Network Failure.....	24

Step 12.3 Enable/Disable the Function of Activate Output Relay 2 when GSM Tower Failure.....	25
Step 12.4 Setting the Parameter for GSM Tower Failure.....	25
Step13- Input Settings.....	26
Step14- Arm and Disarm the System (via Fixed Line Phone).....	27
Step15- Setting the Automatic Call Answering Feature.....	28
6. WT-1010C2 Programming Instructions (Via SMS).....	29
6.1 Time Setting.....	29
6.2 Setting the Account Number for Event Reporting.....	29
6.3 Editing the Message Contents of Auto Test.....	30
6.4 Editing the Input Alert Messages (When High Pulse).....	30
6.5 Editing the Input Alert Messages (When No Pulse).....	31
6.6 Output Settings.....	31
6.6.1 Activate Output Relay to Stay On for a Specific Time.....	31
6.6.2 Activate Output Relay to Stay On Indefinitely.....	32
6.7 Arm and Disarm the System (Via SMS).....	33
7. Miscellaneous Settings.....	34
7.1 Inquire all Programmed Administrator via Voice.....	34
7.2 Deleting the Administrator Number via Voice.....	34
7.3 Changing the Programming Mode Password via Voice.....	34
7.4 Inquire the Status of the Recipients that will receive alert messages via Voice.....	35
7.5 Checking the Signal Strength via Voice.....	35
7.6 Setting the Waiting Time for Engaged Call via Voice.....	35
7.7 Setting Arm Delay Time (Input 1 only).....	36
7.8 Enable/Disable System Power Up SMS Notification	37
7.9 Enable/Disable System Armed SMS Notification	37
7.10 Activate Output Relay to Stay On for a Specific Time via Voice.....	38
7.11 Setting the Alarm Time for Audible Alarm via Voice.....	38
7.12 Setting the WT-1010C2 to Ignore the Front Digits When Dialing the Administrator via Voice.....	39
7.13 Adjusting the Speaker and Microphone Volume via Voice.....	39
7.14 Inquire the Software and Hardware Version of WT-1010C2 via voice.....	40
7.15 Inquire All Programmed Administrator Number via SMS.....	40
7.16 Checking the Signal Strength via SMS.....	40
7.17 Checking the Current Time Status via SMS.....	41
7.18 Changing the Programming Mode Password via SMS	41
7.19 Reset the WT-1010C2 Unit via SMS.....	41
7.20 Inquire the Status of Inputs, PSTN and AC.....	42
8. Technical Specifications.....	42

1. Getting Started

1.1 In the Packaging

Please make sure the following items are included in the packaging:

<u>Name</u>	<u>Quantity</u>	<u>Unit</u>
WT-1010C2 Main Unit	1	set
Telephone line	1	set
DB15 (F) cable	1	set
Power adapter	1	set
5m GSM terminal antenna	1	set
User's Manual	1	CD

1.2 Viewing the WT-1010C2

ANTENNA

The antenna must be well connected before turn on the terminal



NETWORK INDICATOR (GREEN)

The indicator is illuminated when the terminal is connected to GSM Network

POWER INDICATOR (RED)

The indicator is illuminated when mains power is present

2. Introduction to the WT-1010C2 GSM Alarm System

The **WT 1010C2** GSM Terminal is a wireless communicator for alarm and fire panels that uses the cell phone network (GSM) to transmit alarms and other panel event. The module checks the status of the PSTN line and in case the PSTN line becomes unavailable, the **WT 1010C2** GSM emulate the line signal to the panel. At this time, the panel will dial out using the GSM cell phone network to communicate with the receiver at the monitoring station and transmit the alarms.

2.1. GENERAL OVERVIEW

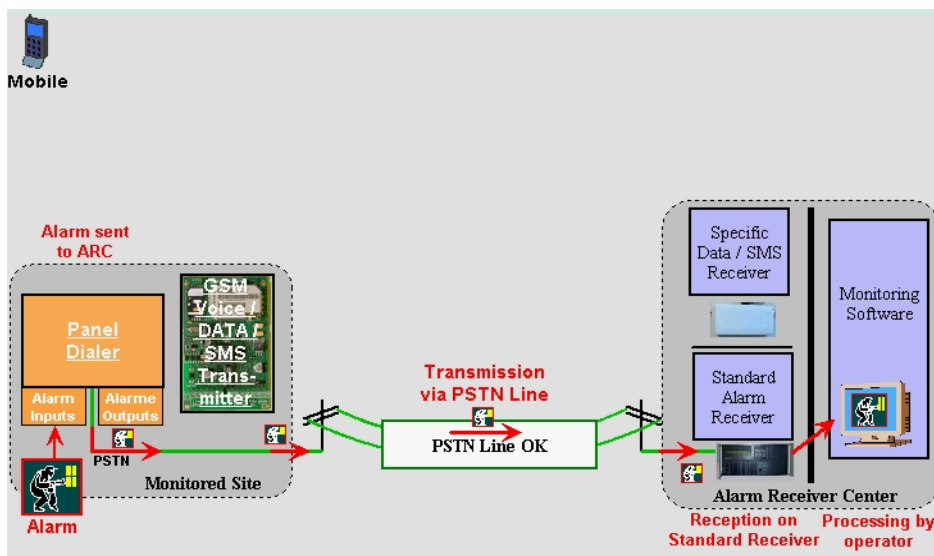
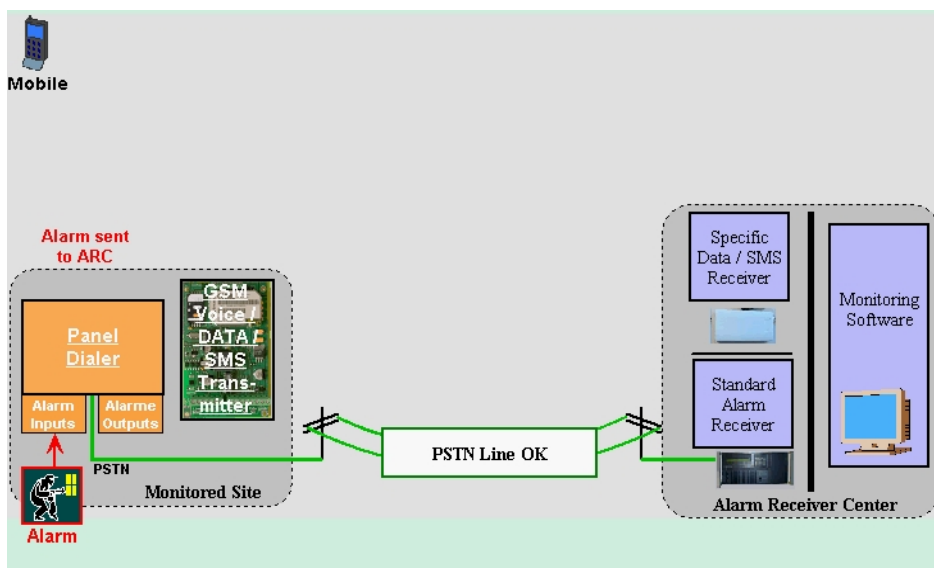

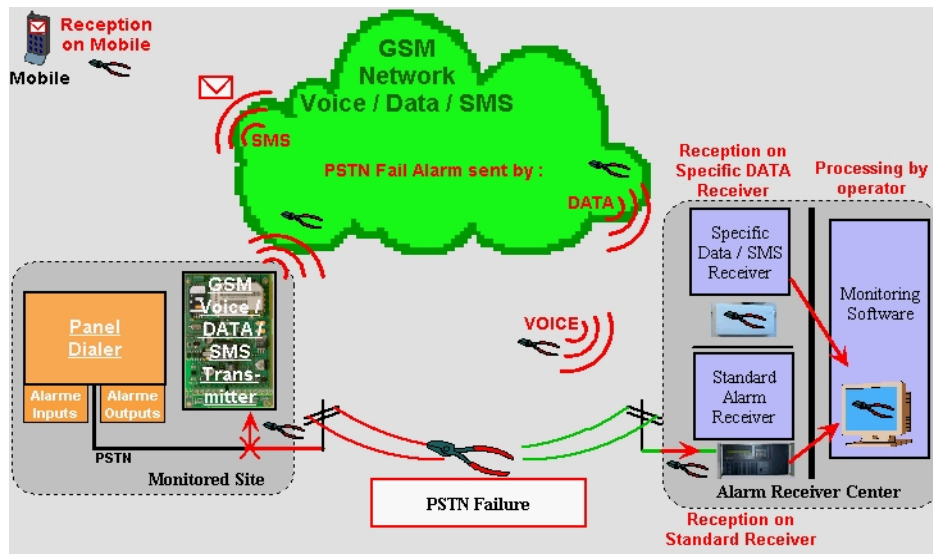

3. Main Features of the WT-1010C2

1. Panel compatibility - Allows any contact ID alarm panel to transmit alarms over GSM using the GSM voice channel
2. Works over the GSM cell phone networks Units can be used wherever there is cell phone coverage
3. Telephone line backup: **WT-1010C2** give priority to the lowest cost network. **WT-1010C2** uses the telephone line as the main transmission line and uses the GSM voice channel as backup
4. Auto restart system: It can continuously monitor the system status of its own. When there is a problem with the SIM card or the module is not working properly, it will automatically restart the system.
5. Programmable Account Number: The **WT-1010C2** has built-in alarm inputs that allow the unit to send additional signals (with user programmable Account number) to the monitoring station. The Alarm Events that available in this system are PSTN Failure, AC Failure and Auto Test. **Supported Protocol: Pager message (DTMF with handshake)**
6. Sends text messages to user programmable cell phone number (SMS): The **WT-1010C2** can be programmed to send a SMS to a programmable cell phone number to notify the user that the PSTN line has been cut off or unavailable.

7. It is possible to arm/disarm the unit remotely via remote control, SMS or phone call. Alternatively, it also can connect to the basic telephone to perform arm/disarm.
8. **Three digital inputs:** The system has the function to send SMS and call to the user in the event of input triggered. For example, Zone 3 connected to an electric door, when there is intruder or the electric door is open illegally, WT-1010C2 will receive short circuit impulse on Zone 3 and automatically sends a signal to the pre-set number and notify the owner.
9. **Three remote control outputs:** These open collector outputs (that can sink max 300ma per output) can be turned on and off remotely through a SMS or phone call. Remote control will be reachable by sending a SMS or phone call with a certain command. For example SMS/Call in to switch on lighting, air conditional, generator, sensor or other equipment.
10. Standby rechargeable battery to prevent power failure or electricity cut off by intruder. The GSM will function as normal when no electricity supply. LCD display to check the GSM signal strength and battery capacity
11. Low power consumption - uses 30mA while in idle state and 260mA when transmitting an alarm
12. Wall mounting enclosure available: The **WT-1010C2** units can be installed inside the alarm panel or inside its own wall mount enclosure.

4. Installation Instructions

Note: It is essential that you read the step by step instructions fully prior to installing and programming the unit

4.1 External Connections Diagram

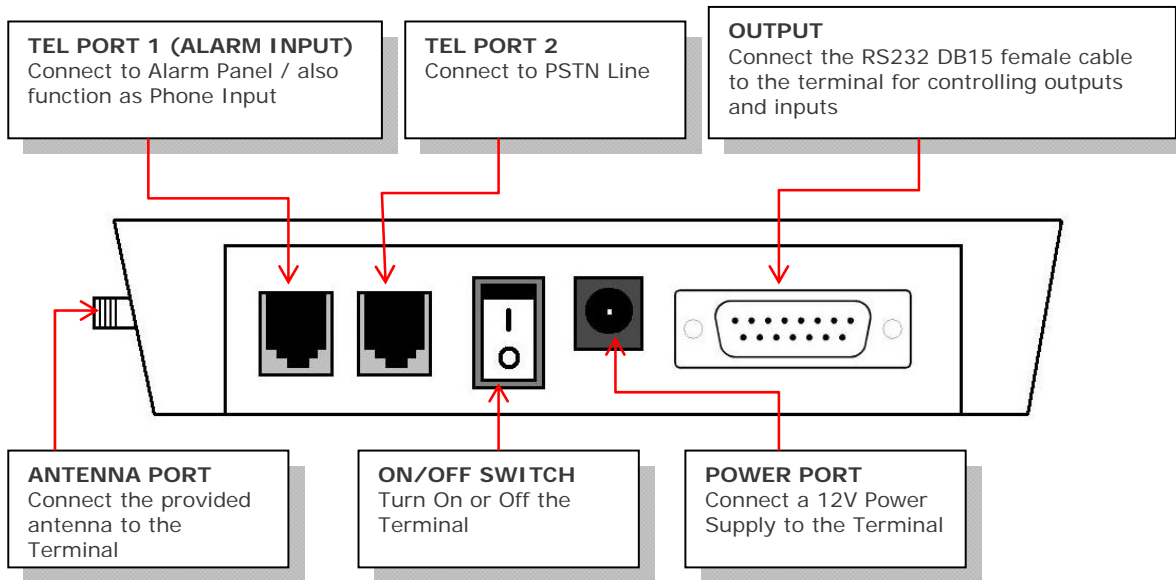

4.2 Wiring Diagram A (Main Unit)

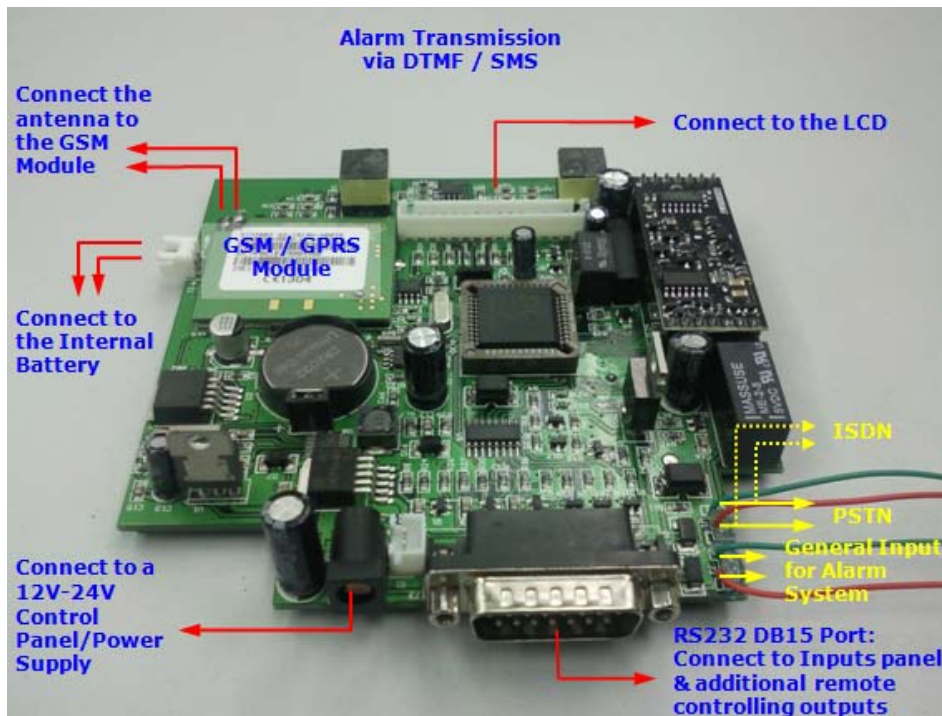

4.3 Wiring Diagram B (View of DB-15 Cable Connector Female Type)

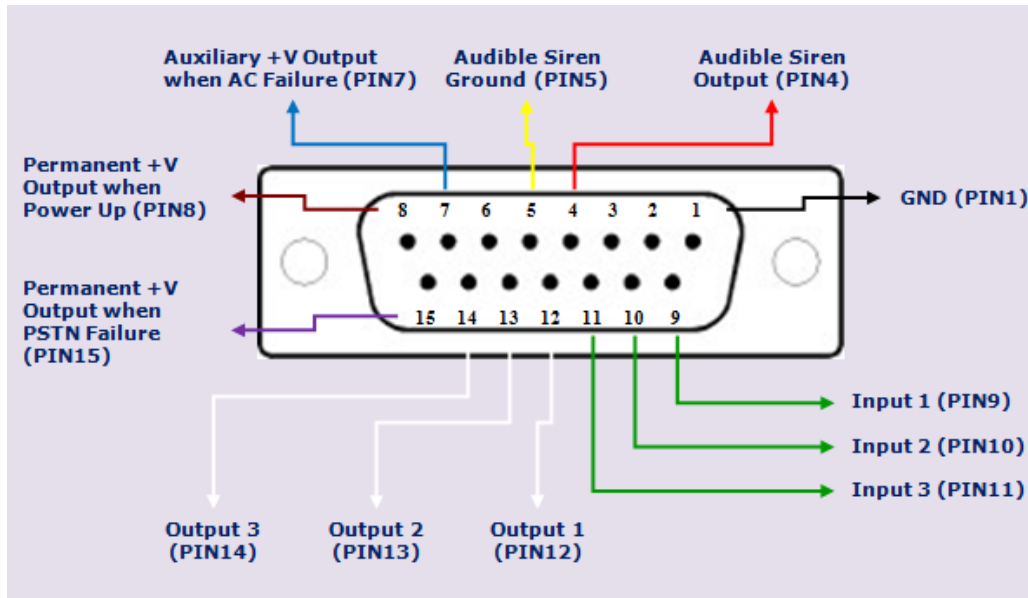

Attention: The color coding on the above indicators will be identical with the actual DB-15 connector cable (Female Type)

4.4 Description

1. **Antenna:** connect the antenna to the GSM module; place the antenna as far as possible from the WT-1010C2 and do not leave any coiling of the antenna cable to avoid radiant interference
2. **SIM Card:** disable the PIN code and set it to 1234 (default)
For Transmitter Mode (Data or SMS): as with any transmitter, it requires an identifier, receiver telephone numbers, etc (refer to the complete information on Programming page)
3. **Line Input:** connect the line input to the PSTN or ISDN network.
4. **Outputs (Back-Up Mode):** connect the RS232 DB15 to additional remote controlling outputs.
5. **Alarm Input:** connect the input to output of the Alarm Panel / Control Panel.
6. **Power Supply:** connect to a 12V power supply
7. **Operating State:** Approximately 20s after power up check the operating state indicated by the Power LED: the LED is steady during power up phase, and then blinks when the connection to the GSM network is established. The Signal indicator LED will stay lit whenever there is signal.

4.5 WT-1010C2 Inputs and Outputs Wiring Instructions

RLY1 (OUT1), RLY2 (OUT2), RLY3 (OUT3) Remote Controlling Outputs

These open collector outputs can be turned on and off remotely through a SMS. Remote control will be reachable by sending a SMS with a certain command.

Note: When sending normal SMS with command below, the WT-1010C2 will turn On / Off the output relay and reply a message of output has turned On / Off to a programmable phone numbers.

ZONE1 (IN1), ZONE2 (IN2), ZONE3 (IN3) Inputs

Connect ZONE1, ZONE2 and ZONE3 to inputs panel, when there is a short-circuit impulse on (ZONE1, ZONE2, ZONE3), the WT1010C2 is possible to send SMS to a programmable phone numbers.

For Example: ZONE3 is connected to an electrical door, when there is intruder or the electrical door is opened illegally, WT1010C2 will receive short-circuit impulse on ZONE3 and will automatically send a signal to the monitoring station and also send a SMS to notify the owner.

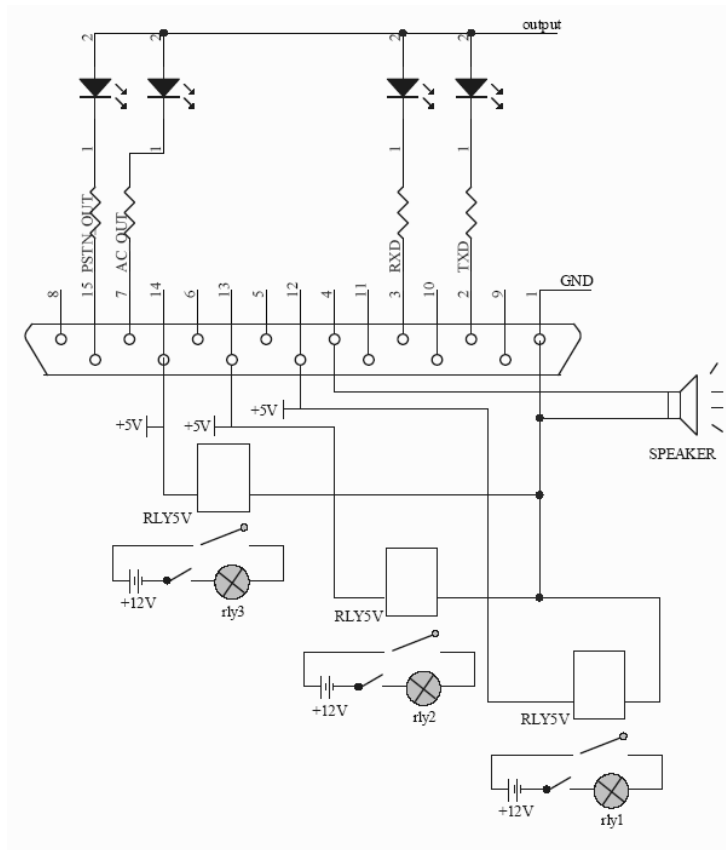

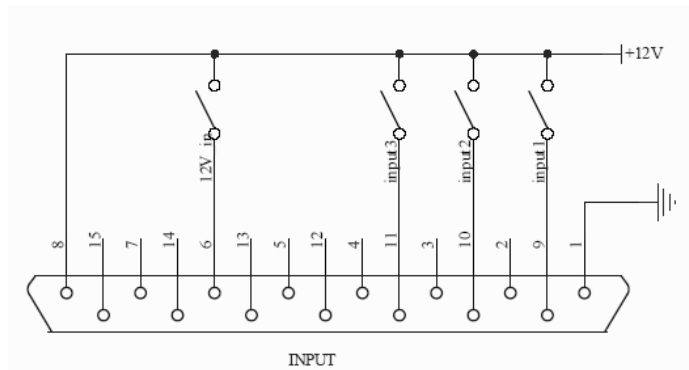

**Inputs & Outputs Wiring Diagram
(View from DB-15 Connector Cable Female Type)**

Permanent +V Output Facility

There is a permanent +V output when the WT-1010C2 is power on. This output is available on the connection PIN8 and ground on the main board. The output voltage is according to power supply used on WT-1010C2. It can be used to power on other facility or device.

4.6 Installing the SIM Card

Note: Installing the SIM Card. Please be sure the initial 4 digit PIN code of SIM card is disabled. This can be done by placing it in an unlocked Mobile phone and first checking if the SIM requested any PIN code. If this is the case the PIN code can be disabled using the security settings on the phone. **Warning!** *The WT-1010C2 identifies only 3V SIM Card.*

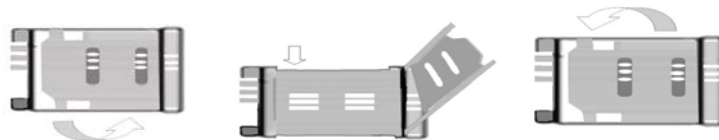

Proceed as follows:

1. Slide back the SIM door and lift it up
2. Slide the SIM card into the SIM door making sure that the clipped corner of the SIM card lines up with the clipped corner of the SIM holder
3. Close the SIM door
4. Slide the SIM door to lock the SIM card in place

4.7 Power up the WT-1010C2

When power up the WT-1010C2, it will display as below

LOADING :>>>>>

WAITING...

When the terminal is ready to use, it will display as below

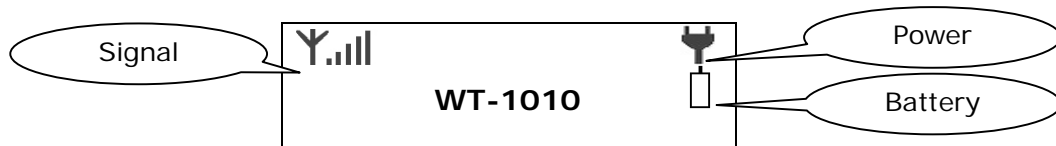

Note: Whenever the WT-1010C2 fails to logon to network or fails to detect the SIM card, it will restart automatically until it has detected the SIM card or successfully logon to network.

4.8 Dialing a number from the attached telephone set

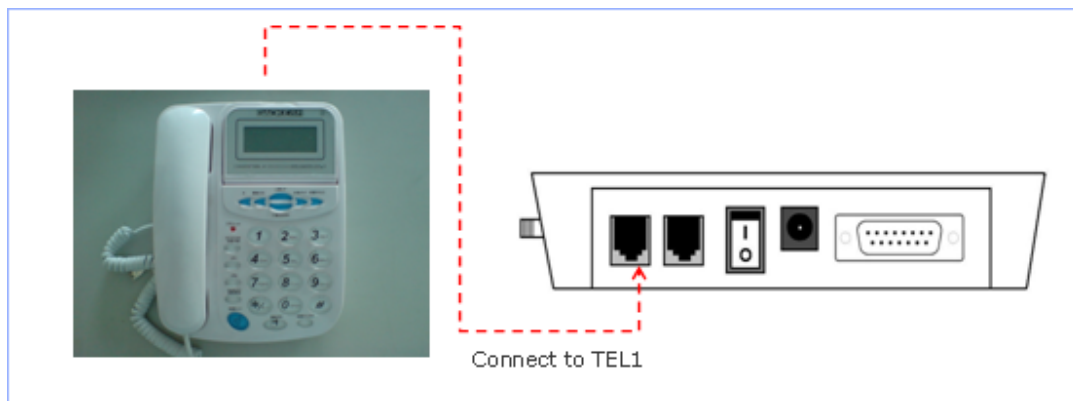

After the GSM module is connected to the GSM network, an attached fixed line phone can be used to make calls. If you pick up the phone, you will hear a dial tone. Simply dial the number you want to call (as if you are dialing from a normal fixed line phone). You can also dial the WT-1010C2 unit's phone number from another phone, and its attached phone will ring as a normal landline phone would. If there is a busy tone on the attached telephone set, either the line you are calling is busy, or the GSM communicator is busy with previous communication at that moment (for example data transfer to the monitoring station).

Note: Some telephone sets are sensitive to the GSM radio signal. For this reason you may hear a characteristic noise in the telephone receiver when calling. If the noise is disturbing, change the location of the phone set (try to keep it as far as possible from the WT-1010C2 unit antenna). Usually it is possible to find a suitable location for the phone with minimal level of interference.

5. WT-1010C2 Configuration Instructions (Via Fixed Line Phone)

5.1 Introduction

The WT-1010C2 can be programmed manually by a connected normal telephone.

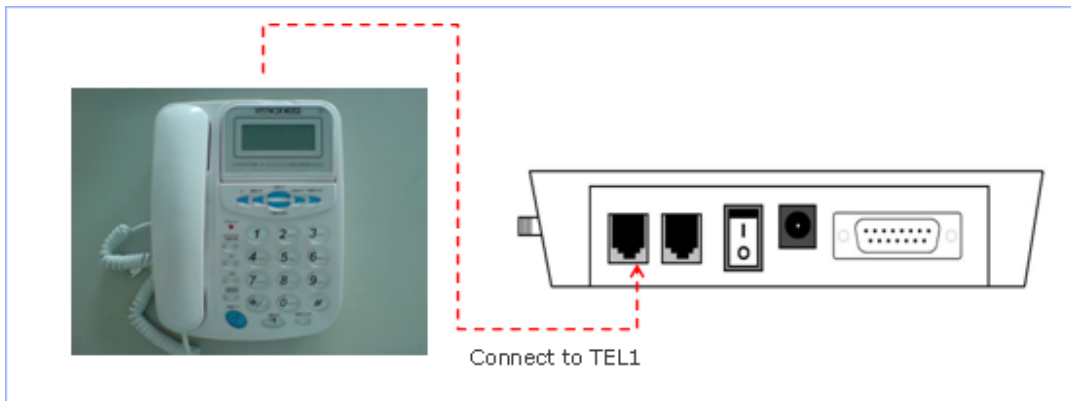

Note: Before commencing programming it is advisable to read the below programming setting instructions thoroughly. To start with programming, user must plug-in a normal single line phone to TEL1 (Port 1)

Step 1. Enter Programming Mode

Pick up the handset or press hands free, press ****123456#** to enter programming mode. If the password has entered correctly, you should see **"HAND FREE..."** displayed on WT-1010C2 screen.

Now you may proceed with programming settings.

**ENTER
SETTING...**

When pick up the handset



ENTER OK
SETTING...

Password entered correctly



HAND
FREE...

Programming Mode

Step 2. Reset the WT-1010C2 Unit

To reset the unit, you can press *15* to proceed.

REST
ON&OFF:



REST
ON&OFF: 1

Then press 1# to reset



REST
ON&OFF: 1 OK

Note: It is advised that you should reset the WT-1010C2 unit before proceeding to the below programming section

Step 3. Programming the Administrator

Continue pressing *1* to start programming the administrator number 1

TEL: 1#



TEL: 13232353646
1#

Enter administrator number **13232353646** for example and ended with #

TEL: OK

Number has programmed successfully

You may continue to program administrator number 2, 3, 4, 5, 6, 7 and 8 by pressing ***2***, ***3***, ***4***, ***5***, ***6***, ***7***, ***8***

Step 4. Setting the Recipient that will receive Alert Messages

The unit can send text alerts to 1 or all 8 of the programmed administrator's numbers. To do this setting, you can press ***18*** to proceed.

SECT:

SECT: 11111111

Example: To turn on this function for all recipients
Simply input **11111111#**

SECT: 11111111
OK

Note: The input for this setting is an **8** digits value: ON (**1**) or OFF (**0**) only. Each of them represents administrator 1 – 8. Default Value: **10000000**

Step 5. Programming the Area Code

To program area code, you can press ***9*** to proceed.

NEW AREA:



NEW AREA: 03

Enter area code **03** for example and ended with **#**



NEW AREA: 03 OK

Area code has programmed successfully

Note: It is possible to program up to 4 digits

Step 6. Setting the Function of Adding Area Code when Transmitting an Alarm

To turn on/off this function, you can press ***14*** to proceed.

AREA
ON&&OFF:



AREA
ON&&OFF: 1

To turn on this function simply press **1#**

To turn off this function simply press **0#**



AREA
ON&&OFF: 1 OK

Default Value: 0

Step 7. Setting the Delay Time for Transmitting a Dialing Number

To set the delay time, you can press ***34*** to proceed.

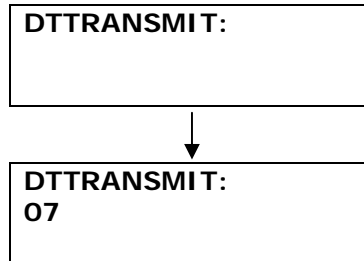

Example: To set the required delay time at 7 seconds
Simply press **07#**

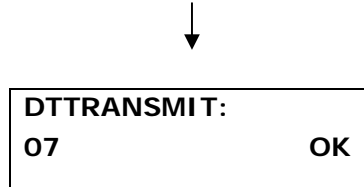

Note: The Delay Time is a 5 digits value range from 00 – 59 seconds (**Default:** 04 seconds)

Step 8. Setting for Calling a Group of Administrator

To program the unit to dial a certain group of numbers for PSTN/AC failure or Auto Test, you can press ***29*** to proceed.

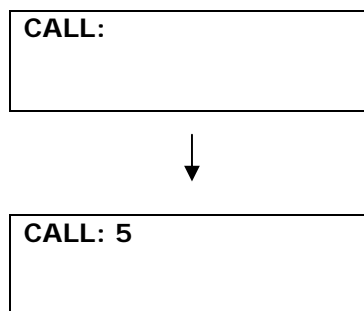

Example: Setting the unit to dial the first 5 administrator
Simply press **5#**

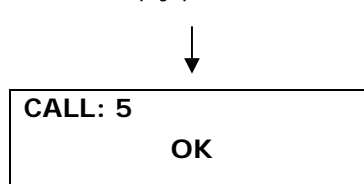

Step 9. Setting for Auto Test

Step 9.1 Time Setting

To setup time, you can press *16* to proceed.

TIME:
: :



TIME:
08 : 30 : 00

Example: To set the time at 8.30am
Simply input digits and ended with #



TIME:
08 : 30 : 00 OK

Step 9.2 Setting the Auto Test Report Time Section 1

The system has the function of sending the test report to the central station at the programmable time section. The time is entered in 24 Hour format. To program the auto test report time section 1, you can press *17* to proceed.

DSTM1:
: :



DSTM1:
12 : 00 : 00

Example: To set the auto test report time at 12.00pm
Simply input digits and ended with #



DSTM1:
12 : 00 : 00 OK

Step 9.3 Setting the Auto Test Report Time Section 2

The system has the function of sending the test report to the Administrator at the programmable time section. The time is entered in 24 Hour format. To program the auto test report time section 2, you can press ***42*** to proceed.

DSTM2:
: :



DSTM2:
18 : 00 : 00

Example: To set the auto test report time at 18.00pm
Simply input digits and ended with #



DSTM2:
18 : 00 : 00 OK

Note: Skip this setting if only 1 time section is needed.

Step 9.4 Setting the Auto Test Report Time Section 3

The system has the function of sending the test report to the Administrator at the programmable time section. The time is entered in 24 Hour format. To program the auto test report time section 3, you can press ***43*** to proceed.

DSTM3:
: :



DSTM3:
23 : 59 : 00

Example: To set the auto test report time at 23.59 pm
Simply input digits and ended with #



DSTM3:
23 : 59 : 00 OK

Note: Skip this setting if only 1 time section is needed.

Step 9.5 Enable/Disable the function of dialing the programmed Administrator number for Auto Test

To turn on this function, you can press ***27*** to proceed.

DTIMEC
ON&&OFF:



DTIMEC
ON&&OFF: 1

To turn on this function simply press **1#**

To turn off this function simply press **0#**



DTIMEC
ON&&OFF: 1 OK

Default Value: 0

Step 9.6 Enable/Disable the generation of SMS Report for Auto Test

To turn on this function, you can press ***28*** to proceed.

DTIMEM
ON&&OFF:



DTIMEM
ON&&OFF: 1

To turn on this function simply press **1#**

To turn off this function simply press **0#**



DTIMEM
ON&&OFF: 1 OK

Default Value: 0

Note: Please refer to programming instructions via SMS for editing the message content of Auto Test

Step 9.7 Setting the Burst On and Burst Off time of DTMF tones

The Burst ON and Burst OFF timing of the sending Contact-ID can be adjust with the below command. To set the Burst on and Burst off time press ***37*** to proceed.

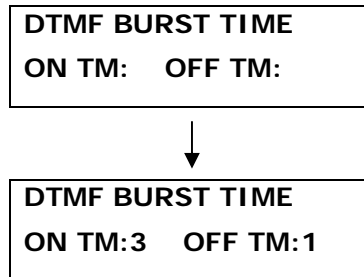

Example: To set the Burst On time at 50~60ms (3) and Burst Off time at 10~20ms (1)

Simply press **31#**

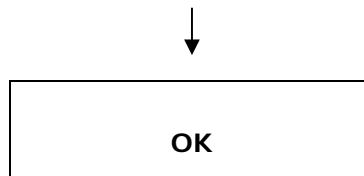

Description:

Value: **1** stands for 10~20ms

Value: **2** stands for 20~40ms

Value: **3** stands for 50~60ms

Value: **4** stands for 60~80ms

Value: **5** stands for 80~100ms

Warning! The WT-1010C2's Contact ID Protocols are complied with the Digital Communication Standard of Ademco. You are advised to go through the Digital Communication Standard here www.smartelectron.ru/files/DC-05_Contact_ID.pdf before proceed with this setting.

Step 10. Setting for PSTN Failure

To turn on this function, you can press ***30*** to proceed.

```
PST: ME:  OU:  AL:
CA1:  CA2:
```



```
PST: ME: 1 OU: 1 AL: 1
CA: 1 CA2: 1
```

Example: Setting the unit to generate an Alert Message, call the administrators, generate a pulse (+V) and sound the audible alarm when PSTN failed.

Simply input **11111#**



```
PST: ME: 1 OU: 1 AL: 1
CA: 1 CA2: 1 OK
```

Description:

“**ME**” stands for generation of SMS when PSTN failed. **Default: 0**

“**OU**” stands for generation of pulse (+V) at PIN15 when PSTN failed. **Default: 0**

“**AL**” stands for sounding the audible alarm when PSTN failed. **Default: 0**

“**CA1**” stands for calling the administrators when PSTN failed. **Default: 0**

“**CA2**” stands for calling the administrators when PSTN connected. **Default: 0**

Value: ON (1) or OFF (0)

Note: Audible Alarm will not work when AC power is unavailable

Auxiliary PSTN Failure Output Facility via PIN15

In addition to the alarm and text alert on PSTN failure the system also has a permanent +V output continuously supplied from the unit via PIN15 output which will remain available for the period of PSTN unavailable.

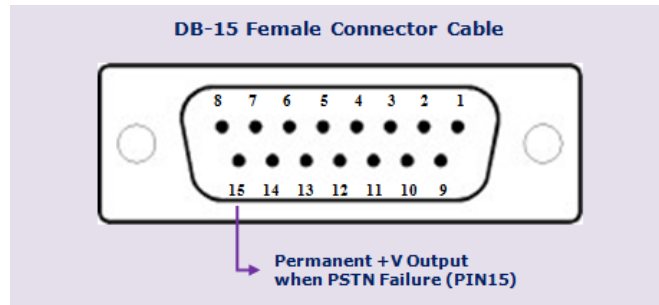

Note: PSTN Failure Output facility can be used on alarm panel for alert notification

Step 11. Setting for AC Failure

To turn on this function, you can press ***31*** to proceed.

```
ADC: ME: AL:
CA1: CA2:
```



```
ADC: ME: 1 AL: 1
CA1: 1 CA2: 1
```

Example: Setting the unit to generate an Alert Message, call the administrators, generate a pulse (+V) and sound the audible alarm when AC failed.

Simply input **1111#**



```
ADC: ME: 1 AL: 1
CA1: 1 CA2: 1 OK
```

Description:

“ME” stands for generation of SMS when AC failed. **Default: 0**

“AL” stands for sounding the audible alarm when AC failed. **Default: 0**

“CA1” stands for calling the administrators when AC failed. **Default: 0**

“CA2” stands for calling the administrators when AC connected. **Default: 0**

Value: ON (1) or OFF (0)

Auxiliary Power Down Output Facility via PIN7

In addition to the alarm and text alert on AC failure the system also has a second permanent +V output continuously supplied from the battery backup via PIN7 output of the unit which will remain available for the period of AC unavailable.

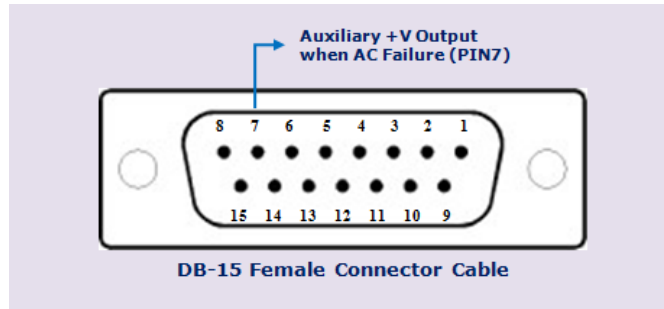

Note: Power Down Output facility can be used on alarm panel for alert notification

Step 12. Setting for Overcoming GSM Jammers & GSM Tower Failure

Step 12.1 Enable/Disable the function of Activate Output Relay 1 when GSM Jammers is detected

To turn on this function, you can press ***38*** to proceed.

NETWORK
ON&&OFF:



NETWORK
ON&&OFF: 1

To turn on this function simply press **1#**

To turn off this function simply press **0#**



NETWORK
ON&&OFF: 1 OK

Step 12.2 Setting the Parameter for Network Failure

To set the parameter, you can press ***39*** to proceed.

NETDT1: RLY1:



NETDT1: 05 RLY1: 05

Example: To set the network failure time for 5 seconds
and the turn on time of Relay 1 for 5 seconds
Simply press **0505#**



NETDT1: 05 RLY1: 05
OK

Description:

"NETDT1" stands for network failure time range from 00 – 59 seconds. **Default:** 6 seconds.

"RLY1" stands for turn on time of Relay 1 when network fails (00 – 59 seconds), 00 means RLY1 will stay ON permanently.

Step 12.3 Enable/Disable the function of Activate Output Relay 2 when GSM Tower Failure

To turn on this function, you can press ***40*** to proceed.

NO SIGNAL
ON&&OFF:



NO SIGNAL
ON&&OFF: 1

To turn on this function simply press **1#**
To turn off this function simply press **0#**



NO SIGNAL
ON&&OFF: 1 OK

Step 12.4 Setting the Parameter for GSM Tower Failure

To set the parameter, you can press ***41*** to proceed.

NETDT2: RLY2:



NETDT2: 06 RLY2: 10

Example: To set the network failure time for 6 seconds
and the turn on time of Relay 2 for 10 seconds

Simply press **0610#**



NETDT2: 06 RLY2: 10
OK

Description:

“NETDT2” stands for network failure time range from 00 – 59 seconds. **Default:** 6 seconds.

“RLY2” stands for turn on time of Relay 2 when network fails (00 – 59 seconds), 00 means RLY2 will stay ON permanently.

Step 13. Input Settings

Turn on the function of Inputs

To turn on the function of input number 1, you can press ***24*** to proceed.

IN1: OP: CL: AL:
CA1: CA2:



IN1: OP: 1 CL: 1 AL: 1
CA1: 1 CA2: 1

Example: Setting the input 1 to generate an SMS, call the administrators
and sound the audible alarm when it triggered.

Simply input **11111#**



IN1: OP: 1 CL: 1 AL: 1
CA1: 1 CA2:1 OK

Description:

"OP" stands for generation of SMS when input triggered (Open). **Default: 0**

"CL" stands for generation of SMS when input triggered (Close). **Default: 0**

"AL" stands for sounding the audible alarm when input triggered. **Default: 0**

"CA1" stands for calling the administrators when input triggered (open). **Default: 0**

"CA2" stands for calling the administrators when input triggered (close). **Default: 0**

Value: ON (1) or OFF (0)

Note: Audible Alarm will not work when AC power is unavailable

You may continue to activate Input 2 and Input 3 functions by pressing *25* or *26*

Note: Please refer to programming instructions via SMS for editing the Input Alert messages

Step 14. Arm and Disarm the System (Via Fixed Line Phone)

To arm the system, you can press *10* to proceed.

ARM OR DISARM
ON&&OFF:



ARM OR DISARM
ON&&OFF: 1

Example: To arm the system simply press 1#

To disarm the system simply press 0#



ARM OR DISARM
ON&&OFF: 1 OK

System armed successfully

Note: In Armed mode, the WT-1010C2 can generate SMS alerts, alarms and dialing the administrator numbers when the inputs triggered, Auto Test, PSTN failed or AC failed.

Alarm Indicator (When dialing the Administrator numbers):

When Input 1 triggered, it will generates (Beep~) continuous sound

When Input 2 triggered, it will generates (Beep~ x 2) continuous sound

When Input 3 triggered, it will generates (Beep~ x 3) continuous sound

When AC failed, it will generates (Beep~ x 5) continuous sound

When PSTN failed, it will generates (Beep~ x 6) continuous sound

When Auto Test, it will generates (Beep~ ~ ~) endless sound

To acknowledge the above alarms simply press the below command on your phone and the system will stop calling you.

***123456#** (Default password: 123456)

Step 15. Setting the Automatic Call Answering Feature

The WT-1010C2 can be programmed to answer all incoming calls automatically even there is no fixed line phone attached to it. When the call is answered, it allows the owner to arm or disarm the system by entering a command from their phone's keypad. To turn on this function, you can press ***35*** to proceed.

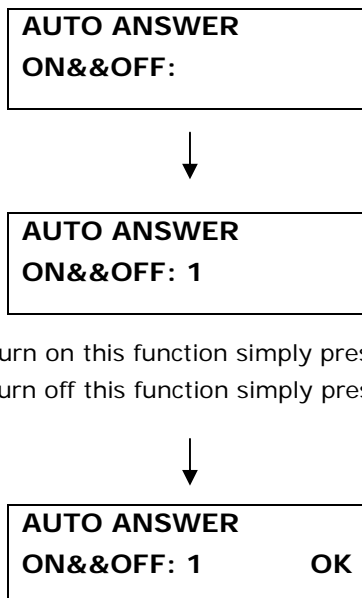

Default Value: 0

Note: Once this function is turned on, the attached fixed line phone will not ring when there is an incoming call.

Arm and Disarm Command via Voice

Press ***123456#** to arm the system when WT-1010C2 answered the call

Press ***123456*** to disarm the system when WT-1010C2 answered the call

Note: 123456 is a 6-digits password that is programmable by ***O*** function or ***PAWO#** command by SMS

6. WT-1010C2 Programming Instructions (Via SMS)

Programming the WT-1010C2 can also be done via SMS commands using your phone. Any programming command sent by SMS must be in **CAPITAL** letters. **The fields between square brackets are parameters; do NOT enter the square brackets.** When you send a command, you will receive the answer for the first time even if your GSM number is not in the administrator list. This happens because the WT-1010C2 recognizes any GSM number as administrator and answers to it.

***Warning!** The administrator number must be programmed into the WT-1010C2 unit first via voice mode in order to use SMS programming mode.*

6.1 Time Setting

To set the time, you can send the following SMS command to the unit. The time is entered in 24 Hour format.

Text Command:

***SETM#HH:MM:SS**

HH stands for 2 digits value: Hour

MM stands for 2 digits value: Minute

SS stands for 2 digits value: Seconds

Example:

When ***SETM#08:30:15** is applied, the time 08:30:15 will be stored inside the WT-1010C2 memory.

Return Message

SETM-OK

6.2 Setting the Account Number for Event Reporting

When PSTN failure, AC failure or Auto Test, the WT-1010C2 will dial the programmable central station number and transmit the account number along with Contact-ID to the central station.

Text Command:

***ACCT#XXXX**

XXXX stands for Account Number (Can be set up to 50 digits)

Example:

To set an account number 9999 into the system, you would send the following SMS message to the unit.

***ACCT#9999**

Return Message

ATACC:9999

Note: For Contact-ID Protocol details please refer to www.smartelectron.ru/files/DC-05_Contact_ID.pdf

6.3 Editing the Message Contents of Auto Test (Up to 50 Characters)

The message contents can be edited and programmed up to 50 characters. You can change the displayed text by sending the following commands by SMS message to the unit. **Note:** Only support normal abc/ABC English text, no special characters.

Text Command:

***TSMS#XXXXXX...**

XXXXXX... stands for message contents

Example:

If you want the SMS Report to display "**Status:Online**", you would send the following SMS message to the unit.

***TSMS#Status:Online**

Return Message

TSMS=Status:Online

6.4 Editing the Inputs Alert Messages (When High Pulse)

The Input Alert Message can be edited and programmed up to 50 characters. You can change the displayed text by sending the following commands by SMS message to the unit. **Note:** Only support normal abc/ABC English text, no special characters.

Text Command:

***USE[N]#XXXXXX...**

N stands for Input number **1 – 3**

XXXXXX... stands for alert message content

Example:

If you want the alert message to display “**Garage Opened!**” when input **1** triggered; you would send the following SMS message to the unit.

***USE1#Garage Opened!**

Return Message

USE1=Garage Opened!

6.5 Editing the Inputs Alert Messages (When No Pulse)

The Input Alert Message can be edited and programmed up to 50 characters. You can change the displayed text by sending the following commands by SMS message to the unit. *Note: Only support normal abc/ABC English text, no special characters.*

Text Command:

***USC[N]#XXXXXX...**

N stands for Input number **1 – 3**

XXXXXX... stands for alert message content

Example:

If you want the alert message to display “**Garage Closed!**” when input **1** triggered; you would send the following SMS message to the unit.

***USC1#Garage Closed!**

Return Message

USC1=Garage Closed!

6.6 Output Settings

6.6.1 Activate Output Relay to Stay On for a Specific Time

To activate the output relay, you can send a text command via SMS specifying the number of seconds the output should stay on to the unit. It is possible to set up to maximum of 99,999 seconds

Text Command:

***RLY[N]#XXXXX**

N stands for Output number **1 - 3**

XXXXX stands for **5** digits value: The number of seconds (00000-99999)

For example, assume you want to turn on the output relay number 2 for 1 hour, you would send the following SMS message to the unit.

***RLY2#03600**

Return Message

***RLY2#=03600**

Sending the following SMS Message to unit would mean turn off the output relay number 1.

***RLY1#00000**

6.6.2 Activate Output Relay to Stay On Indefinitely

To activate the output relay to stay on indefinitely, you can send the following text command via SMS to the unit.

Text Command:

***RLY[N]#ON**

N stands for Output number **1 - 3**

For example, assume that you want output relay number 1 to stay on indefinitely, you would send the following SMS message to the unit.

***RLY1#ON**

To switch off the output relay, you can send the following text command via SMS to the unit.

Text Command:

***RLY[N]#OFF**

N stands for Output number **1 - 3**

For example, to switch off output relay number 2, you would send the following SMS message to the unit.

***RLY2#OFF**

6.7 Arm and Disarm the System (Via SMS)

It is possible to arm and disarm the system by SMS. You can send the following text command to unit.

Text Command:

***DARM#X**

X stands for ON (**1**) or OFF (**0**) value

Example:

To arm the system, you can send the following text message to the unit.

***DARM#1**

Return Message

ARM

To disarm the system, you can send the following text message to the unit.

***DARM#0**

Return Message

DISARM

7. Miscellaneous Settings

7.1 Inquire All Programmed Administrator via Voice

To inquire all administrator numbers, you can press ***32*** to proceed.

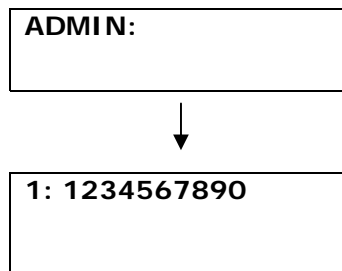

All the administrator numbers will be displayed in sequence

7.2 Deleting the Administrator Number via Voice

Example: To delete the programmed administrator number 1, you can press ***1*** to proceed.

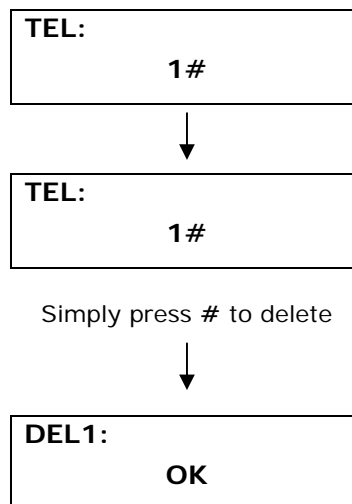

7.3 Changing the Programming Mode Password via Voice

To change the 6 digits programming mode password, you can press ***0*** to proceed.

NEW PASSWORD:



NEW PASSWORD:

654321

Input new password and ended with #



NEW PASSWORD:

654321 OK

7.4 Inquire the status of the Recipients that will receive Alert Messages via Voice

To inquire the status of the recipients, you can press ***19*** to proceed.

RECIPIENTS:

11111111

The status will be displayed on screen

Press # to turn back

7.5 Checking the Signal Strength via Voice

To check the signal strength, you can press ***20*** to proceed.



CSQ <23>

The signal strength will be displayed on screen

Press # to turn back

7.6 Setting the Waiting Time for Engaged Call via Voice

In the event the administrator has not answered the call or engaged, it could take a while for the WT-1010C2 to call the next number. You can shorten the time for every call by programming the waiting time. Press ***12*** to proceed.

WAIT TIME:



WAIT TIME: 20

Example: To set the waiting time for 20 seconds
Simply input 20 and ended with #



WAIT TIME: 20
OK

Note: The waiting time is a 2 digits value range from 20 – 59 seconds (**Default:** 30 seconds)

7.7 Setting Arm Delay Time (Input 1 Only)

Input 1 can be programmed to arm after a preset time when the Arm button is pressed or Arm function is activated by fixed line phone. To program the delay time, you can press *45* to proceed.

ARM TIME:



ARM TIME: 30

Example: To set the arm delay time for 30 seconds
Simply input 30 and ended with #



OK

Note: The Arm Time is a 2 digits value range from 00 – 59 seconds (**Default:** 00 seconds)

7.8 Enable/Disable System Power Up SMS Notification

The system is able to generate SMS notification whenever the WT-1010C2 is turned on. To enable this function, you can press ***46*** to proceed.

POWER UP MSG
ON&&OFF:



POWER UP MSG
ON&&OFF: 1

To enable this function simply press **1#**
To disable this function simply press **0#**



POWER UP MSG
ON&&OFF: 1 OK

Default Value: 0

7.9 Enable/Disable System Armed SMS Notification

The system is able to generate SMS notification whenever user armed the WT-1010C2. To enable this function, you can press ***47*** to proceed.

ARM MESSAGE
ON&&OFF:



ARM MESSAGE
ON&&OFF: 1

To enable this function simply press **1#**
To disable this function simply press **0#**



ARM MESSAGE
ON&&OFF: 1 OK

Default Value: 0

7.10 Activate Output Relay to stay on for a specific time via Voice

To activate output relay 1 to stay on for a specific time, you can press ***21*** to proceed.

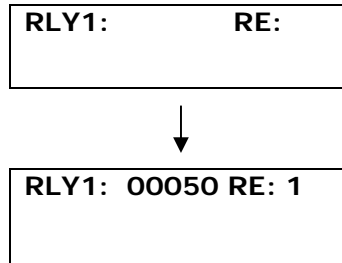

Example: To activate relay 1 to stay on for 50 seconds and with SMS reply from the unit after relay has turned off

Simply input **000501#**

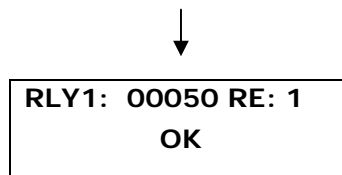

Note: "RE:" stands for generation of SMS when relay off, value: ON (1) or OFF (0)

You may continue to activate relay 2 or relay 3 by pressing ***22*** or ***23***

7.11 Setting the Alarm Time for Audible Alarm via Voice

To set the alarm time for audible alarm, you can press ***33*** to proceed.

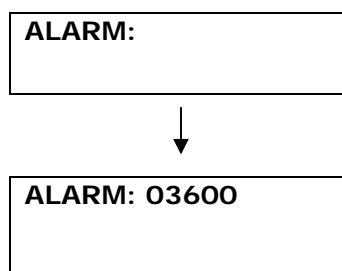

Example: To set the audible alarm to sound for 1 hour when triggered

Simply press **03600#**

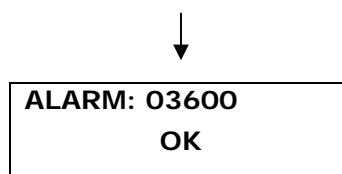

Note: The alarm time must enter in 5 digits range from 00001 – 99999 (**Default:** 00010 seconds)

7.12 Setting the WT-1010C2 to ignore the front dialing digits when dialing the Administrator via Voice

This function is useful when the WT-1010C2 is connected to the PABX system where Access Digits are required for Extension Line/Centrex Line. To set the unit to ignore the front dialing digits, you can press ***44*** to proceed.

DEL-NUM:



DEL-NUM: 2

Example: To set the unit to ignore first 2 dialing digits
Simply press **2#**



DEL-NUM: 2
OK

Note: The value is 0 – 4 (Default: 0)

7.13 Adjusting the Speaker and Microphone Volume level via Voice

To adjust the speaker and microphone volume level, you can press ***11*** to proceed.

SPK: MIC:



SPK: 3 MIC: 3

Example: To adjust the speaker volume to 3 and microphone volume to 3
Simply press **33#**



SPK: 3 MIC: 3
OK

Note: Both SPK and MIC volume level range from 1 – 4 (**Default:** 1). Adjust the speaker and microphone volume to compatible with your alarm panel

7.14 Inquire the Software and Hardware Version of WT-1010C2 via Voice

To check the software and hardware version of WT-1010C2 unit, you can press ***13*** to proceed.

HW: 1.1ver SW: 1.0 ver MW: 1.5ver
--

The information will be displayed on screen

Press # to turn back

7.15 Inquire All Programmed Administrator Number via SMS

To inquire all the programmed administrator, you can send the following SMS command to the unit.

Text Command:

***ADM?#**

Example of Return Message

1: 13256997049

2: 15915325252

3: 13456679988

4:

5:

6:

7:

8:

7.16 Checking the Signal Strength via SMS

To check the signal strength of the unit, you can send the following SMS command to the unit.

Text Command:

***CSQ?#**

Example of Return Message

CSQ=<28>

7.17 Checking the Current Time Status via SMS

To check the current time, you can send the following SMS command to the unit.

Text Command:

***ASTM#**

Example of Return Message

TIME-01:35:50

7.18 Changing the Programming Mode Password via SMS

It is possible to change the login password by sending the following SMS command.

Text Command:

***PAWO#XXXXXX**

XXXXXX stands for **6** digits New Password

Example:

To change the password to **654321**, you would send the following SMS command to the unit.

***PAWO#654321**

Return Message:

PAWO-OK

7.19 Reset the WT-1010C2 unit via SMS

To reset the unit, you can send the following command by SMS to the unit.

Text Command:

***REST#XXXXXX**

XXXXXX stands for 6 digits password based on ***PAWO#** (Default: **123456**) and it can be changed anytime.

Return Message**REST-OK****7.20 Inquire the Status of Inputs, PSTN and AC**

To inquire the status of inputs, PSTN and AC, you can send the following SMS command to the unit.

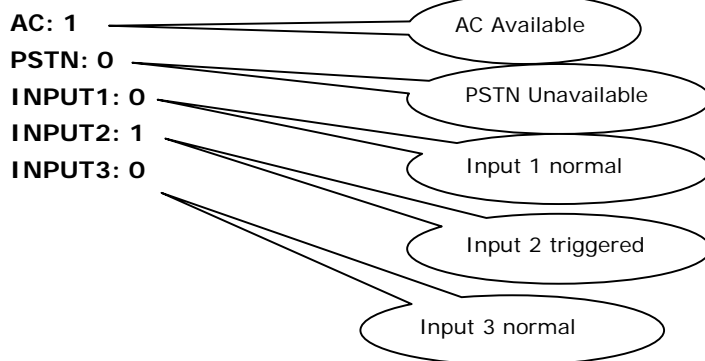
Text Command:***CTC?#**Example of Return Message**8. Technical Specifications**

1. Environment temperature: 0~ +50°C
2. Relative humidity: 10%~95%
3. Air pressure: 86~106kpa
4. Environment yawp: ≤60dB (A)
5. Working frequency: GSM900MHz/GSM1800MHz
6. Stability of frequency: better than 2.5PPM
7. Signal sensitivity: -103dBm
8. Transmit power: <2w
9. Power: 220v±15% AC
10. Input Voltage Tolerances: 1~20VDC
11. The max distance between terminal and telephone: 100M

Warranty

Witura Corporation Sdn Bhd guarantees all WT-1010C2 GSM Fixed Wireless Terminal against defective parts and workmanship. Witura Corporation Sdn Bhd shall, at its option, repair or replace the defective equipment upon the return of such equipment to any Witura branch. This warranty applies ONLY to defects in components and workman-ship and NOT to damage due to causes beyond the control of Witura, such as incorrect voltage, lightning damage, mechanical shock, water damage, fire damage, or damage arising out of abuse and improper application of the equipment.

Note: Wherever possible, return only the PCB to Witura Service Centres.
DO NOT return the enclosure.

The WT-1010C2 is a product of
Witura Corporation Sdn Bhd
And is manufactured by
Shenzhen Witura Telecommunications Co., Ltd.

WARNING

For safety reasons, only connect equipment with a telecommunications compliance label. This includes customer equipment previously labelled permitted or certified.